

ROCK'N MOON RALLY™



OWNERS AND SERVICE MANUAL **INNOVATIVE CONCEPTS IN ENTERTAINMENT INC.**

10123 MAIN STREET, CLARENCE, NY 14031

SERVICE: 1-716-759-0360

FAX: 1-716-759-0884

E-MAIL: service@icegame.com

WEBSITE: www.icegame.com

TABLE OF CONTENTS

| | |
|-----------------------------------|--------------|
| INTRODUCTION..... | PAGE 3 |
| • GAME FEATURES | |
| • GAME PLAY | |
| INSTALLATION..... | PAGE 4 |
| • BEFORE YOU BEGIN | |
| • TOOLS NEEDED | |
| • INSTALLATION | |
| PROGRAMMING OPTIONS..... | PAGE 5 |
| • INTRODUCTION | |
| • HOW TO ADJUST OPTIONS | |
| • USING THE PROGRAMMING OPTIONS | |
| • CALCULATION FORMULA | |
| MAINTENANCE..... | PAGE 6 |
| • OVERVIEW | |
| QUICK TROUBLESHOOTING..... | PAGE 7 & 8 |
| GAME REPAIR..... | PAGE 9 - 12 |
| • OPERATIONAL BACKGROUND | |
| • TROUBLESHOOTING PHILOSOPHY | |
| • MECHANICAL REPAIR | |
| PARTS LISTINGS..... | PAGE 13 |
| SCHEMATICS / WIRING DIAGRAMS..... | PAGE 14 - 39 |
| WARRANTY INFORMATION..... | PAGE 40 & 41 |

INTRODUCTION

GAME FEATURES

Thank you for purchasing the new **Rock' N Moon Rally™** from I.C.E. This new game utilizes all the proven technology of its predecessor Spacey Racers™. ICE has reduced the size giving the customer a fresh look with full reliability. ICE'S research and development department focused heavily on all the problem areas of the Spacey Racers™. This would insure that **Rock' N Moon Rally™** would be as trouble free for the customer as possible.

Game cabinetry is stylish, yet bright. The game has been designed to be either a back-to-back centerpiece or a wall unit that will enhance the look of any location. Thick 16 gauge metal panels and marine grade water resistant plywood make the game extremely durable.

One of ICE'S major improvements was a chain guide insert. This new insert will actually encompass the chain in the area where it wore first. The idea was to have the chain rubbing on a material specially designed for this application. In the unlikely case that the insert would begin to wear, the insert could be easily replaced rather than the whole track.

The moon like terrain is made of a special high impact ABS that is easy to maintain. The sheer fact that it is a color thru part and not painted means it will hide scratching and blemishes well. The playfield surface that the bikes ride on is .032 back-printed polycarbonate.

Quality and endurance were the major factors in selecting the drive motor. The motor being the heart and soul of the game, needed to be "bullet proof". Bison gear was the manufacturer selected. After 3 years and thousands of revolutions, none have been replaced in the field.

Electronics and sounds are the state of the art in digital technology. Robust design ensures a long trouble free life for your game. The game is very flexible with its programming options to allow it to be tailored to most locations easily.

GAME PLAY

The game begins when a player or players inserts the correct number of coins to equal one credit. The object of the game is to race your character around the track by rolling the track ball as fast as you can. In some instances a player will be competing directly with the person next to him, in others he will be competing with the computer controlled player. Whatever way the game ends up being played, it will be a competitive and thrilling race for all.

NOTE: The direction in which the track ball is rolled will not have any effect on the direction that the character is moving. The character will move forward no matter what direction the track ball is rolled in. A player may lose valuable time trying to roll the trackball in the exact direction the character is traveling.

INSTALLATION

BEFORE YOU BEGIN

WARNING: WHEN INSTALLING THIS GAME, A 3 PRONG GROUNDED A.C. RECEPTACLE MUST BE USED. FAILURE TO DO SO COULD RESULT IN INJURY TO YOURSELF OR OTHERS. FAILURE TO USE A GROUNDED RECEPTACLE COULD ALSO CAUSE IMPROPER GAME OPERATION, OR DAMAGE TO THE ELECTRONICS

DO NOT DEFEAT OR REMOVE THE GROUNDING PRONG ON THE POWER CORD FOR THE SAME REASON AS GIVEN ABOVE. USING AN IMPROPERLY GROUNDED GAME COULD VOID YOUR WARRANTY.

HAVE A QUALIFIED ELECTRICIAN CHECK YOUR A.C. RECEPTACLE TO BE SURE THE GROUND IS FUNCTIONING PROPERLY.

THIS GAME IS DESIGNED TO DISSIPATE STATIC ELECTRICITY THROUGH THE GROUNDING PLANE OF THE GAME. IF THE A.C. GROUND DOES NOT WORK, THE GAME COULD DISCHARGE STATIC ELECTRICITY THROUGH THE GAME CIRCUITRY, WHICH COULD CAUSE DAMAGE.

TOOLS NEEDED

- 7/16 Socket or box wrench
- Phillips screwdriver
- Square drive bit
- Pliers

INSTALLATION

The game comes ready to play with just a few simple things to keep in mind.

1. When installing the game, be sure you use a grounded A.C. outlet. If necessary,

have it checked to be sure the ground is good.

2. Make sure the game is level after installation. It is necessary to make sure the game is level so the game will work properly.

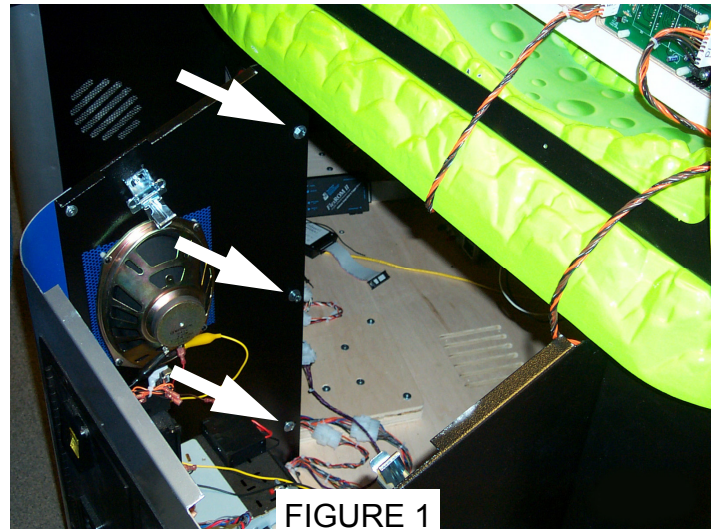

3. The game normally comes with the control panels/podiums inside the lower cabinet. A 7/16 wrench or socket is needed to attach the podiums to the lower cabinet. (See figure 1)

TO OPERATE THE GAME AT VOLTAGES OTHER THAN THOSE IT WAS DESIGNED FOR, PLEASE CONTACT OUR SERVICE DEPARTMENT FOR VOLTAGE CONVERSION INFORMATION.

Plug the game into the A.C. outlet and turn power to the game on. The switch for the game is located on a power module inside the game.

It is now time to program your game.....

PROGRAMMING OPTIONS

INTRODUCTION

The **Rock' N Moon Rally™** game is extremely flexible from a programming standpoint. This allows the customer to “fine tune” the game to his or her exact needs.

This section will describe in detail each of the programming options and how they work.

PLEASE READ THIS SECTION THOROUGHLY BEFORE CALLING OUR SERVICE DEPARTMENT. MOST QUESTIONS REGARDING SET-UP AND OPERATION WILL BE FULLY EXPLAINED BELOW.

HOW TO USE THE PROGRAMMING OPTIONS

PROGRAMMING BUTTON – Use this button to enter and exit the programming mode. Press this button once to enter the mode, and once again to exit the mode.

SELECT BUTTON – Use this button to scroll through and “step” through the various options.

ADVANCE BUTTON – Use this button to “change” the value of a particular option.

| <u>OPTION</u> | <u>DEFAULT.</u> | <u>MIN</u> | <u>MAX</u> | <u>DEFINITION</u> |
|---------------|-----------------|------------|------------|---------------------------------|
| 0 | 5 | 00 | 11 | Volume adjustment (0=off) |
| 1 | 1 | 00 | 11 | Volume Attract Mode (0=off) |
| 2 | 2 | 01 | 08 | Credits per Game |
| 3 | 2 | 01 | 08 | DBV or second coin switch |
| 4 | 20 | 00 | 50 | Tickets winner 2-player race |
| 5 | 11 | 00 | 50 | Tickets loser 2-player race |
| 6 | 15 | 00 | 50 | Tickets winner 1-player race |
| 7 | 08 | 00 | 50 | Tickets loser 1-player race |
| 8 | 1 | 01 | 02 | # of laps per race |
| 9 | 1 | 01 | 03 | Difficulty (3=adult 1=child) |
| 10 | 2.7 | 00 | 50 | Player 1 finish line adjustment |
| 11 | 3.2 | 00 | 50 | Player 2 finish line adjustment |
| 12 | 00 | 00 | 01 | Factory reset |

NOTE: After the factory reset has been selected, the programming button must be pressed twice to exit. There will be a delay before the game starts.

MAINTENANCE

GENERAL MAINTENANCE

This game has been designed to be as trouble and maintenance free as possible.

With this in mind the only basics are to keep the game clean. Below are the main areas to take care of with specific directions.

MARQUEE

The MARQUEE should be cleaned with a soapy water solution if covered with water-based dirt such as food products. After cleaning with soapy water, polish with a commercial plastic polish or a spray furniture polish. These have lubricating oils that condition the plastic and keep it shiny and clear looking. Never use regular glass cleaners as the ammonia in them actually damages the plastic and dulls it.

CABINET

The cabinet plastic and decals can be cleaned with soapy water or spray furniture polish. **DO NOT** use any alcohol or petroleum based cleaners as they could damage the plastic or printed parts.

COIN MECHANISMS

The coin mechanisms should be cleaned periodically, as they will accumulate dirt, which will cause the coins to stick.

Remove the coin mech and clean them in a dish detergent solution and a stiff brush. Dry thoroughly and re-install.

TICKET DISPENSERS

The biggest problem ticket dispensers have is ticket dust blocking the optical detectors. It is a good idea to occasionally use compressed air to remove the dust from the dispensers.

CHARACTER / PLAYFIELD

ICE recommends that the operator take special care when handling the characters. It is not necessary to clean them. The only time they should be removed from the game is when the playfield is being cleaned.

When cleaning the playfield, it is also very important to **ONLY** use a damp cloth with water or alcohol. **DO NOT** use any wax or polish, this may cause the wheels to slide. As a result the playfield will wear or the tires will get flat spots. ICE will not warranty any parts if these instructions are not followed.

LUBRICATION

ICE insists that WD-40 is the only lubricant used on the track. This lubricate works well with the chain and plastic combination. WD-40 will evaporate over time, which is important to the performance of the track. Track lubrication should be performed at least once every 6 months.

Other lubricants will tend to attract dirt and dust; as a result this can cause premature wearing of the track or jamming.

ICE also recommends lubrication and cleaning of the trackball bearings.

Trackball lubrication - use light weight motor or all purpose oil.

QUICK TROUBLESHOOTING

GAME WILL NOT TAKE OR ADD MONEY CORRECTLY

- Micro switch not working or returning properly. Check and repair or replace as necessary.
- Bad Harnessing or connector. Check w/ohm meter and repair as necessary.
- Game programming set incorrectly. Check programming option and re-program if necessary.
- Bad Main P.C. Board. Check and repair or replace as necessary.

GAME HAS NO SOUND

- Bad speaker. Check w/ohm meter for 4 or 8-ohm load. If not within this range, replace.
- Volume level set incorrectly. Check volume level in programming, and adjust if necessary.
- Bad Harnessing or connector. Check w/ohm meter and repair as necessary.
- Bad Main P.C. Board. Check and repair or replace as necessary

TICKET DISPENSER DOES NOT WORK OR WORKS IMPROPERLY

- Bad ticket dispenser. Repair or replace as necessary.
- Bad harnessing or connector. Check w/ohm meter and repair as necessary.
- Bad Main P.C. Board. Check and repair or replace as necessary.
- Game out of tickets. Add tickets
- Optical sensor on ticket dispenser dirty. Remove paper fuzz and debris with a soft brush.

NO FLORESCENT LIGHTING

- Bulb burned out. Replace bulb.
- Electronic ballast bad. Replace ballast.
- Harness bad or harness unplugged. Check w/ohm meter and plug in, repair or replace as necessary.
- No A.C. power to the game or Main fuse bad. Check fuse and A.C. power.

MARQUEE DOES NOT LIGHT

- Fuse blown on main P.C. Board. Replace fuse.
- Harnessing between marquee and main board bad. Check and repair as necessary.
- Bad Marquee P.C. Board. Repair or replace as necessary.

TICKETS OR HIGH SCORE DISPLAY DON'T WORK PROPERLY

- Bad Display P.C. Board. Repair or replace Display board
- Bad Main P.C. Board. Repair or replace Main board.
- Bad display harnessing. Repair as necessary.

CAN'T ENTER OR EXIT PROGRAMMING OR OTHER ADJUSTMENT MODES

- Bad programming or adjustment buttons. Replace buttons. Check harnessing.
- Harnessing fell off back of button. Re-attach harnessing.
- Bad Main P.C. Board. Repair or replace Main board.

QUICK TROUBLESHOOTING

ERROR MODE

| MODE | DESCRIPTION | CONDITION & SOLUTION |
|------|----------------|---|
| E1 | NVRAM | |
| E2 | HOME SWITCH #1 | REPLACE OR ADJUST (VAPOR) |
| E3 | HOME SWITCH #2 | REPLACE OR ADJUST (RETRO) |
| E4 | MOTOR OPTO #1 | BAD MOTOR, OPTO BOARD, LOOSE OPTO WHEEL, POSSIBLE BAD MAIN BOARD |
| E5 | MOTOR OPTO #2 | BAD MOTOR, OPTO BOARD, LOOSE OPTO WHEEL, POSSIBLE BAD MAIN BOARD |
| E6 | ANNOUNCER HOME | HOME SWITCH IS NOT WORKING POSSIBLY NOT BEING MADE |
| E7 | TRACK BALL #1 | OPTO ON THE "X" AXIS IS NOT WORKING PROPERLY, REPLACE OPTO BOARD, LOOSE OPTO WHEEL, DIRTY, CHECK CONNECTION |
| E8 | TRACK BALL #1 | OPTO ON THE "Y" AXIS IS NOT WORKING PROPERLY, REPLACE OPTO BOARD, LOOSE OPTO WHEEL, DIRTY, CHECK CONNECTION |
| E9 | TRACK BALL #2 | OPTO ON THE "X" AXIS IS NOT WORKING PROPERLY, REPLACE OPTO BOARD, LOOSE OPTO WHEEL, DIRTY, CHECK CONNECTION |
| E10 | TRACK BALL #2 | OPTO ON THE "Y" AXIS IS NOT WORKING PROPERLY, REPLACE OPTO BOARD, LOOSE OPTO WHEEL, DIRTY, CHECK CONNECTION |
| E11 | COIN 1A | COIN SWITCH STUCK DOWN, BROKEN OR JAMMED |
| E12 | COIN 1B | COIN SWITCH STUCK DOWN, BROKEN OR JAMMED |
| E13 | COIN 2A | COIN SWITCH STUCK DOWN, BROKEN OR JAMMED |
| E14 | COIN 2B | COIN SWITCH STUCK DOWN, BROKEN OR JAMMED |

GAME REPAIR

WARNING: ALWAYS REMOVE POWER TO THE GAME BEFORE ATTEMPTING ANY SERVICE, UNLESS NEEDED FOR SPECIFIC TESTING.

FAILURE TO OBSERVE THIS PRECAUTION COULD RESULT IN SERIOUS INJURY TO YOURSELF OR OTHERS.

OPERATIONAL BACKGROUND

The **Rock' N Moon Rally™** game has been manufactured with modular design in mind. Almost everything in the game can be EASILY removed for servicing. This makes it much easier for the repairman as he / she can work in a quieter less distracting environment away from the Game Room floor.

Coin, low ticket and home position sensing are done with conventional micro switches.

All P.C. Boards are made of premium quality board material and use time proven components to assure you of the most reliable designs possible.

We have put forth our best efforts and tested this game extensively to assure the best possible performance under the widest variety of operating conditions. We are ALWAYS however, interested in our customers input for product improvement. If you have any questions or comments please feel free to contact our service department.

I.C.E. SERVICE DEPARTMENT

716-759-0360

NORMAL BUSINESS HOURS ARE:
MONDAY – FRIDAY, 9:00 AM TO 6:00 PM EST

TROUBLESHOOTING PHILOSOPHY

To find problems with the game, always first check what should be obvious. See that the game is plugged in, and that all of the fuses on the game are good. This includes the fuse that is located INSIDE the power module.

Next, check to see that all of the connectors are firmly seated and that none of the wires have been pulled out of them. This will help you to know if you have a problem with a specific component, or maybe a problem with either the wiring or the Main P.C. Board.

Use extreme caution when using probes or voltmeters if the game is powered up. If doing continuity checks, it is important to disconnect the harnessing at both ends, as attached they may yield erroneous results.

If a P.C. Board is suspected as the cause of a problem, check to see that all of the components on the board are firmly attached. Pay special attention to any socketed devices.

If light bulbs are suspected, swap them with one that is known to work to narrow the problem down to either a bulb or P.C. Board.

GAME REPAIR

REPLACEMENT & REPAIR

TRACK MOTORS

To remove the track motors:

1. Unplug the opto board and motor wires.

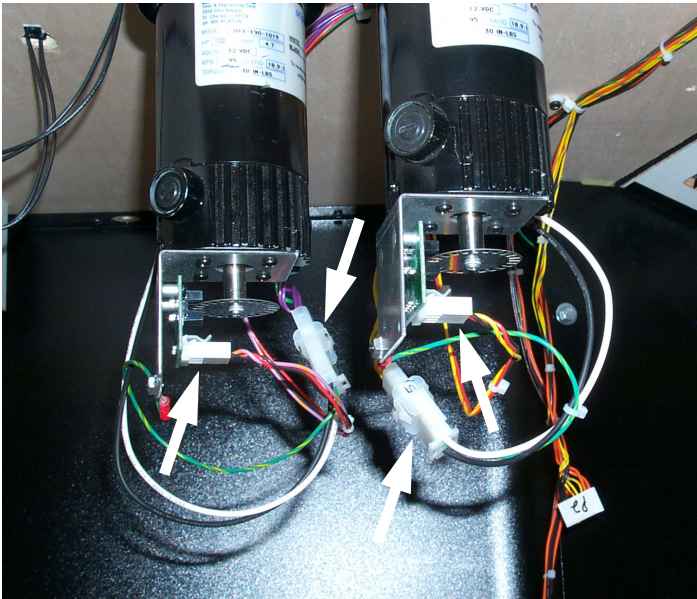

2. Remove the four Phillips head screws that hold the motor, and then remove the motor.

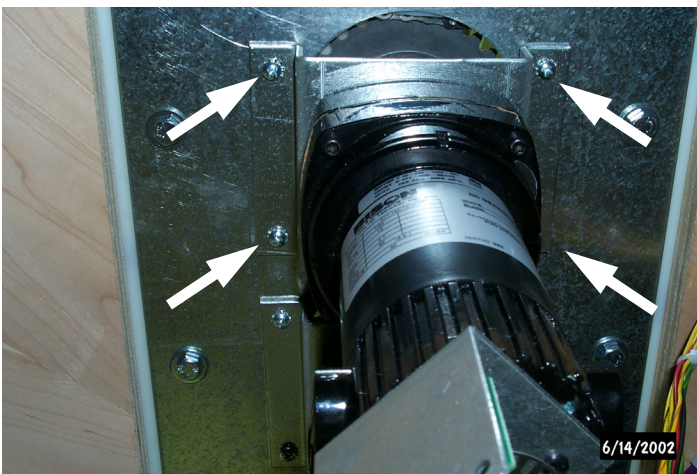

CHAIN BED INSERT REPLACEMENT

Service the coil bed as follows:

1. Remove the four 1/4-20 bolts in the rear of the game.

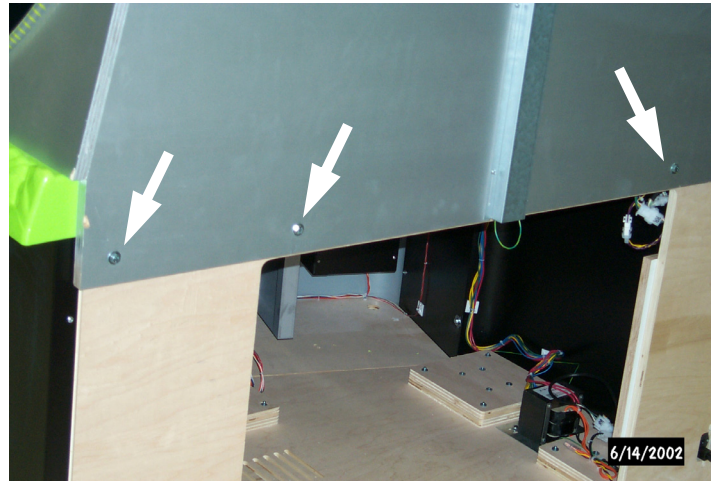

2. Remove the front glass at each control station. Then remove the 1/4-20 bolts holding the upper cabinet in place.



GAME REPAIR

3. Open the rear access door to disconnect the harnessing.

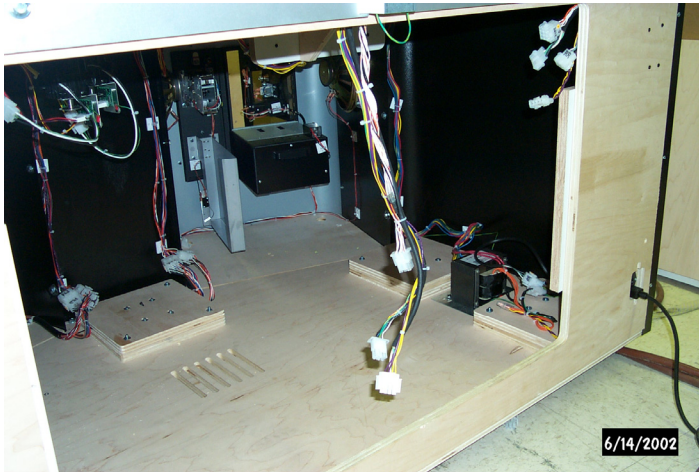

4. Remove the tricycles from the playfield.
5. Carefully lift the upper cabinet assembly from the lower portion of the game.



5. Remove the playfield.



6. Follow the motor replacement instruction to remove the track motors.
7. Remove both chains and you are ready to replace the insert.

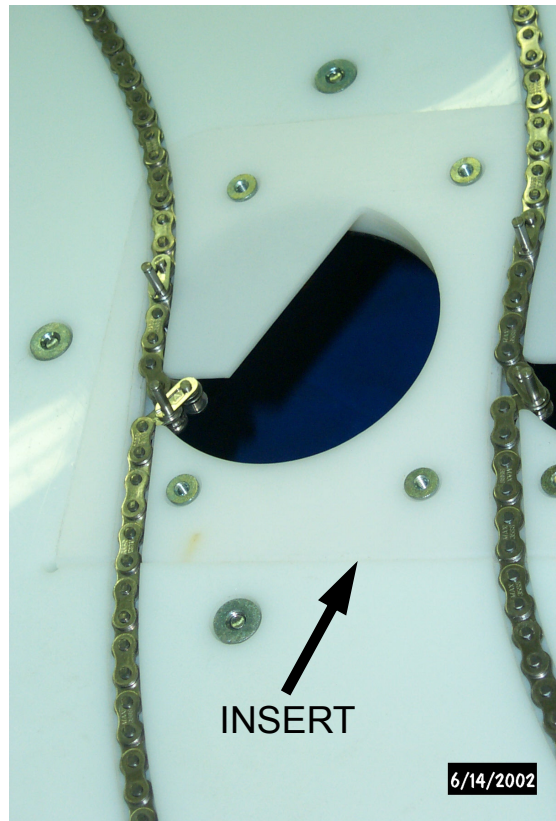

GAME REPAIR

MARQUEE BULB / DISPLAY BOARD SERVICE

1. Remove the upper plex cover on the marquee. Then replace the burnt out bulb. Be sure to put the plex cover back in its original position.

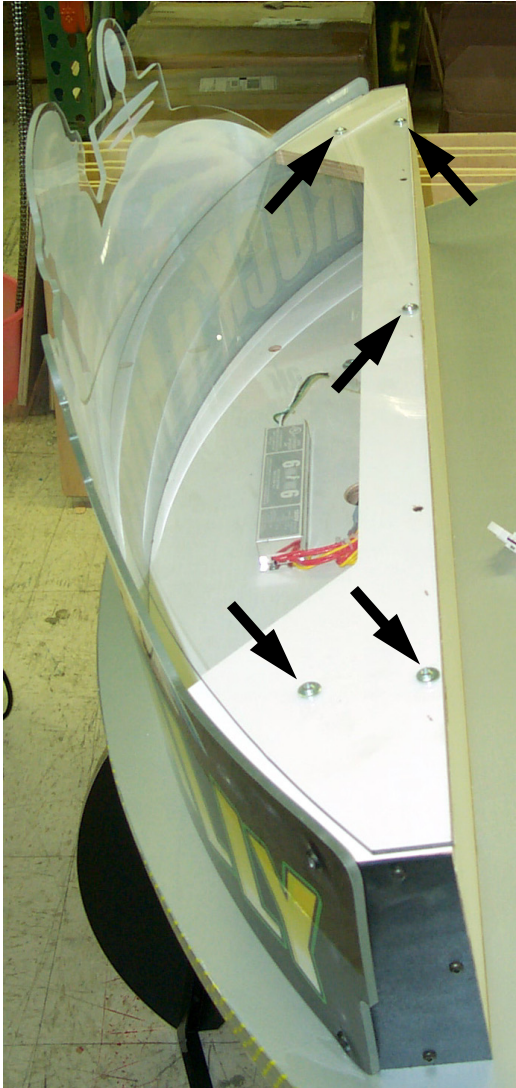

IF YOU HAVE ANY QUESTIONS OR COMMENTS, PLEASE CONTACT OUR SERVICE DEPARTMENT AT:

716-759-0360

MON. THRU FRI. 9:00 AM - 6:00 PM EST

PARTS LISTINGS

MECHANICAL PARTS

| | |
|---------|-------------------------------------|
| 211 | Low Ticket Micro Switch |
| PP250X | PLL Bulb Socket Assembly |
| FP1004 | Leg Leveler Mounting Bracket |
| HR1019 | Leveler Foot |
| RR1024 | Ticket Bin |
| AR2007 | Speaker, 6" x 9" |
| BW2017 | PLL Bulb Retaining Clip |
| BW2018 | PLL Bulb Support |
| 8312* | Bulb, PL-L 40W/41/RS/IS Fluorescent |
| CC2027 | Power Cord, 20ft. |
| 5101X | Mech Holder Assembly |
| 175 | Imonex 950/. 25 mech. |
| BW8284X | Workhorse 6 Ballast, (WH6-120-L) |
| HH5005 | Ticket Dispenser |
| RR1008 | Track Insert |
| RR1052 | Sprocket (A6M7RL28825) |
| SR4003X | Character Assembly (Retro) |
| SR4004X | Character Assembly (Vapor) |

ELECTRONIC / ELECTRICAL

| | |
|---------|-------------------------------|
| RR2034X | Main Board |
| SR2035 | Track Ball & Motor Opto Board |
| SR2008 | Motor |
| HH2043 | Lock Out Coils |
| SR2001A | Track Ball Assembly |

DECALS AND GRAPHICS

| | |
|--------|-----------------------|
| RR7001 | Control Panel (Retro) |
| RR7002 | Control Panel (Vapor) |
| RR7003 | Track - Outer |
| RR7004 | Track - Inner |
| RR7010 | Lower Cabinet Side |
| RR7014 | Lower Cabinet Front |
| RR7027 | Marquee |

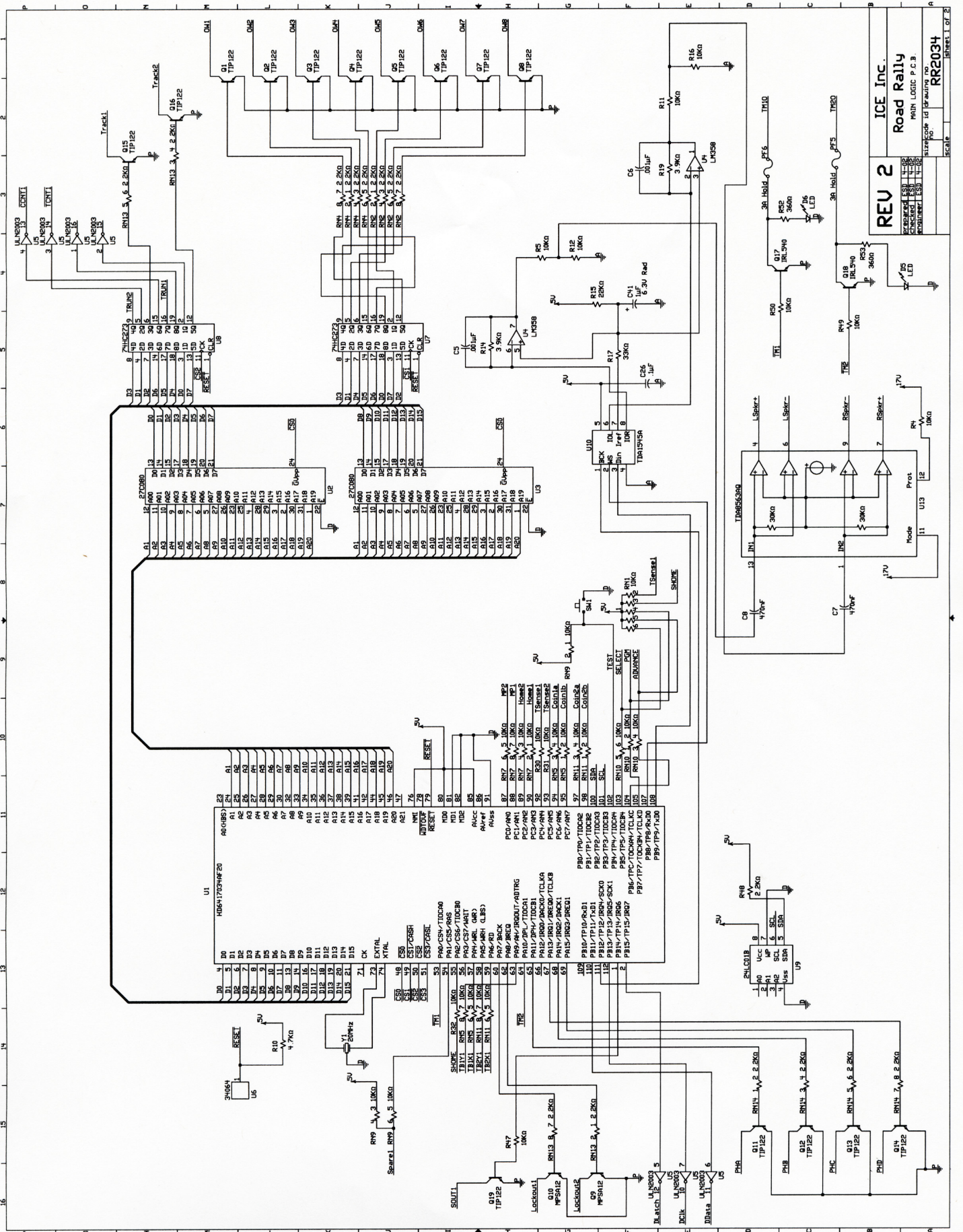

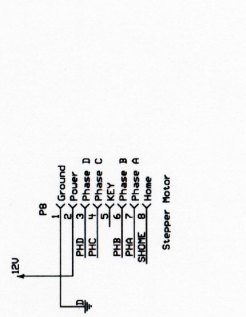
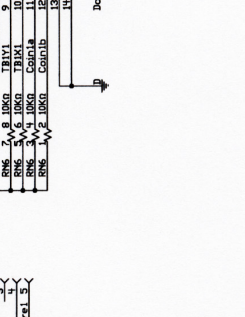
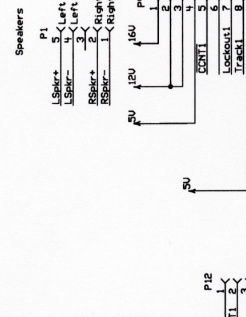
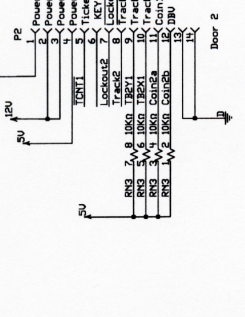
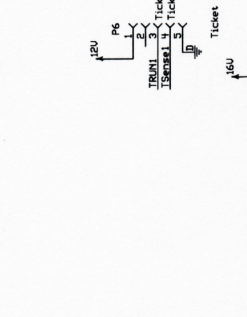
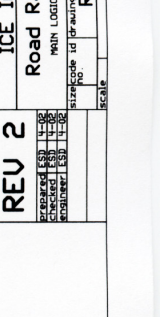
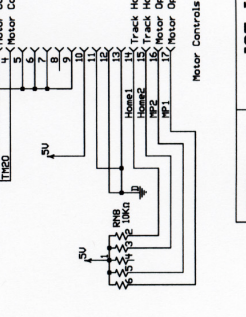
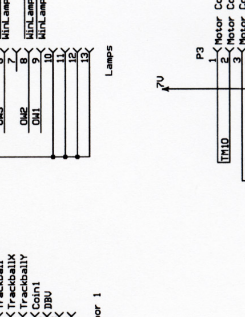
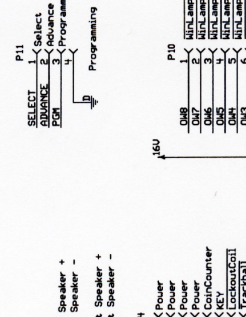
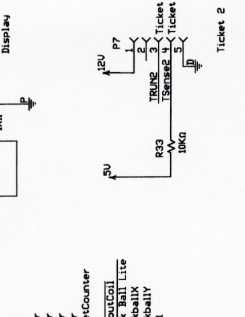
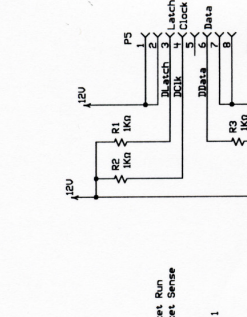
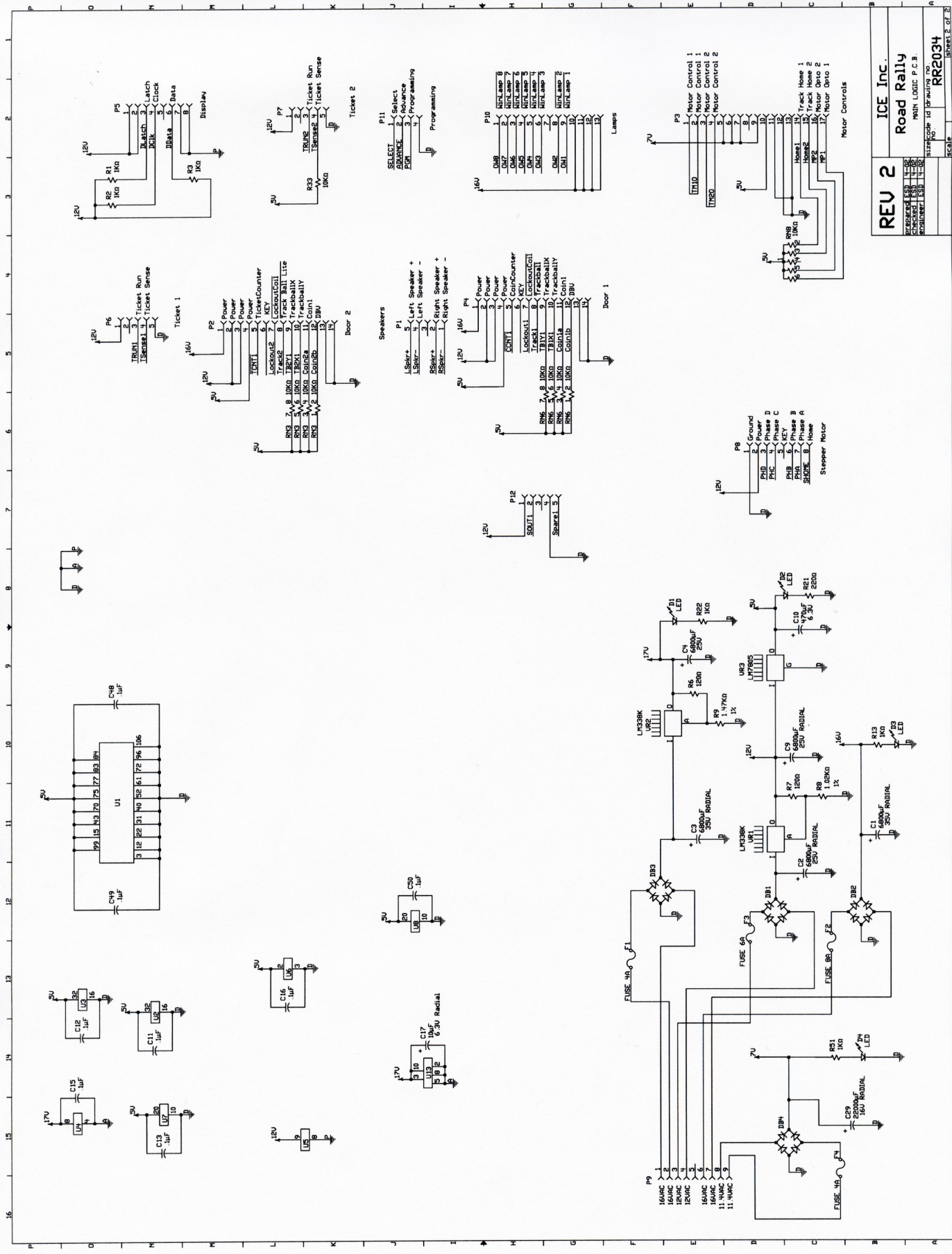

REV 2 ICE Inc.
Road Rally
 MAIN LOGIC P.C.B.
 PCB LAYOUT
 DATE: 12/15/83
 DRAWN: L.S.D.
 CHECKED: L.S.D.
 APPROVED: L.S.D.
 SIZE: 10.0 x 10.0
 FILE NO: RR2034
 SHEET 2 OF 2

1
2
3
4

D C B A

60"

TO MAIN BOARD

- | P9 | 1 | 2 | 3 | 4 | 5 | 6 | 7 | 8 | 9 |
|----|--------------|--------------|----------------|----------------|---------------|---------------|------------------|------------------|---|
| | GREEN | GREEN | BLUE | BLUE | RED | RED | YELLOW | YELLOW | |
| | 16 VAC @ 4 A | 16 VAC @ 4 A | 12 VAC @ 4.5 A | 12 VAC @ 4.5 A | 16 VAC @ 10 A | 16 VAC @ 10 A | 11.4 VAC @ 7.5 A | 11.4 VAC @ 7.5 A | |

9 PIN PLUG #2292
20-14 AWG MALE #8260

TO BASE OF TRANSFORMER

GREEN/YELLOW #PC20217
17"

TO POWER MODULE

3 PIN PLUG #2206
SOLID PIN #2100S
PINS 1&3:20-14 MALE #8260

16"

ORANGE
#2817 - SPLICE CAP
(BUCHANAN #2006S)
#2818 - SPLICE CAP INS
(BUCHANAN 2007)

16"

TO HALOGEN LIGHTS

40"
4 PIN CAP #2101
FEMALE PIN #2102

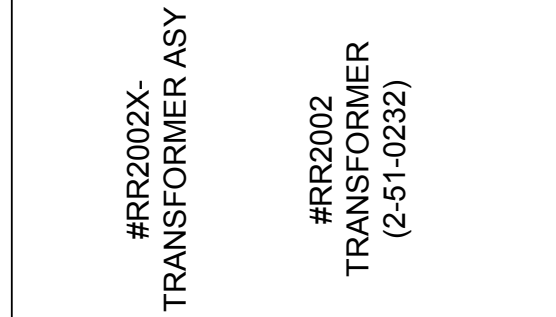
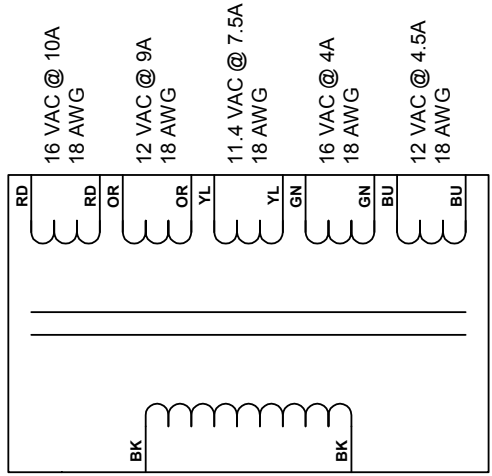

| | | | |
|-------------|-----------------------------|----------|--------------|
| TITLE | ROCK N MOON RALLY | | |
| DESCRIPTION | #RR2002X - TRANSFORMER ASY. | FILENAME | RR.VSD |
| DATE | 8/15/01 | DRAWN BY | MMARTIN |
| | REVISED | 6/17/02 | PAGE 1 OF 24 |

1
2
3
4

1 2 3 4

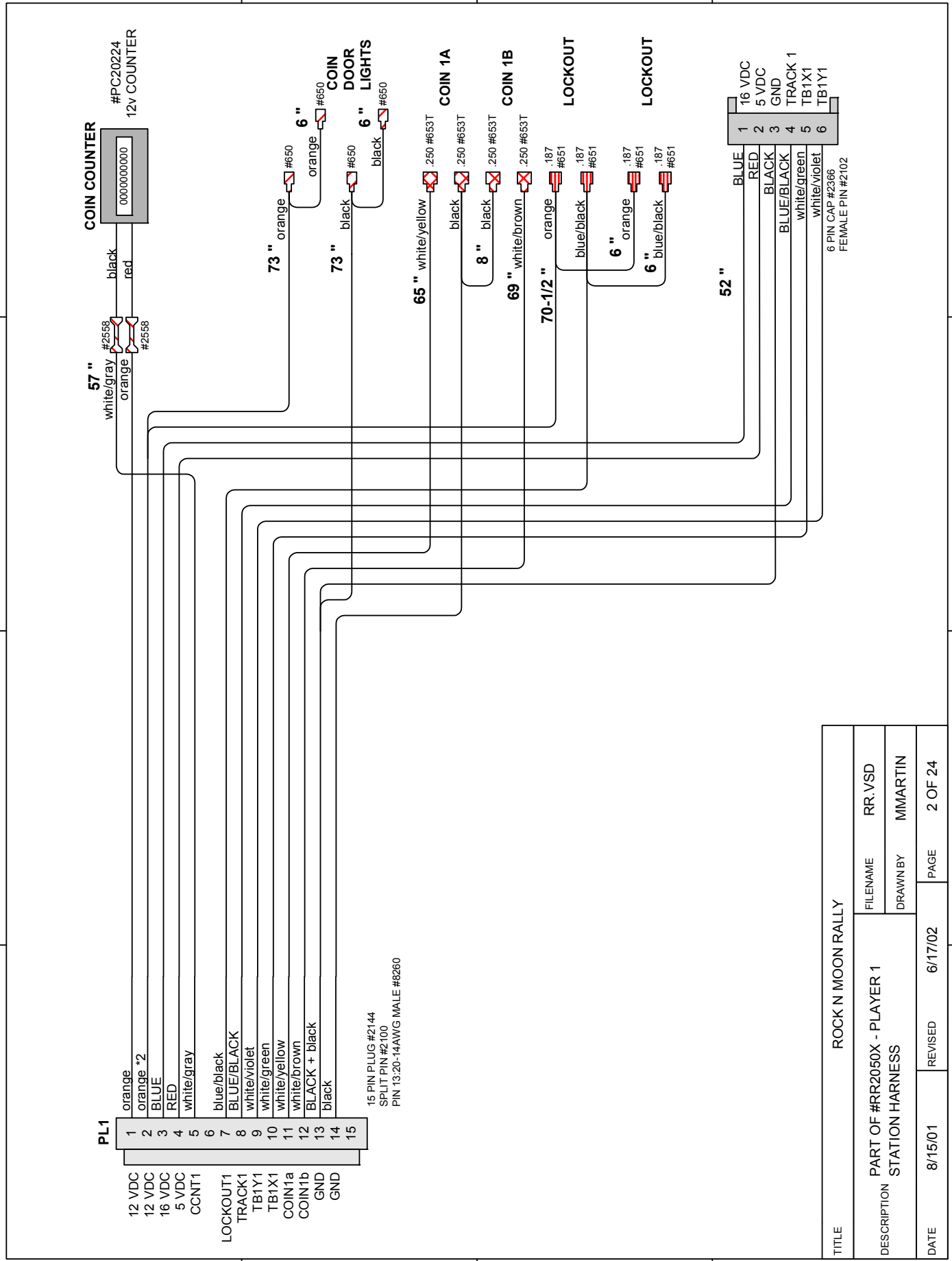

1 2 3 4

| | | | |
|-----------------|---------|-------------------|---------|
| TITLE | | ROCK N MOON RALLY | |
| DESCRIPTION | | FILENAME | RR.VSD |
| STATION HARNESS | | DRAWN BY | MMARTIN |
| DATE | REVISED | PAGE | 2 OF 24 |
| 8/15/01 | 6/17/02 | | |

1 2 3 4

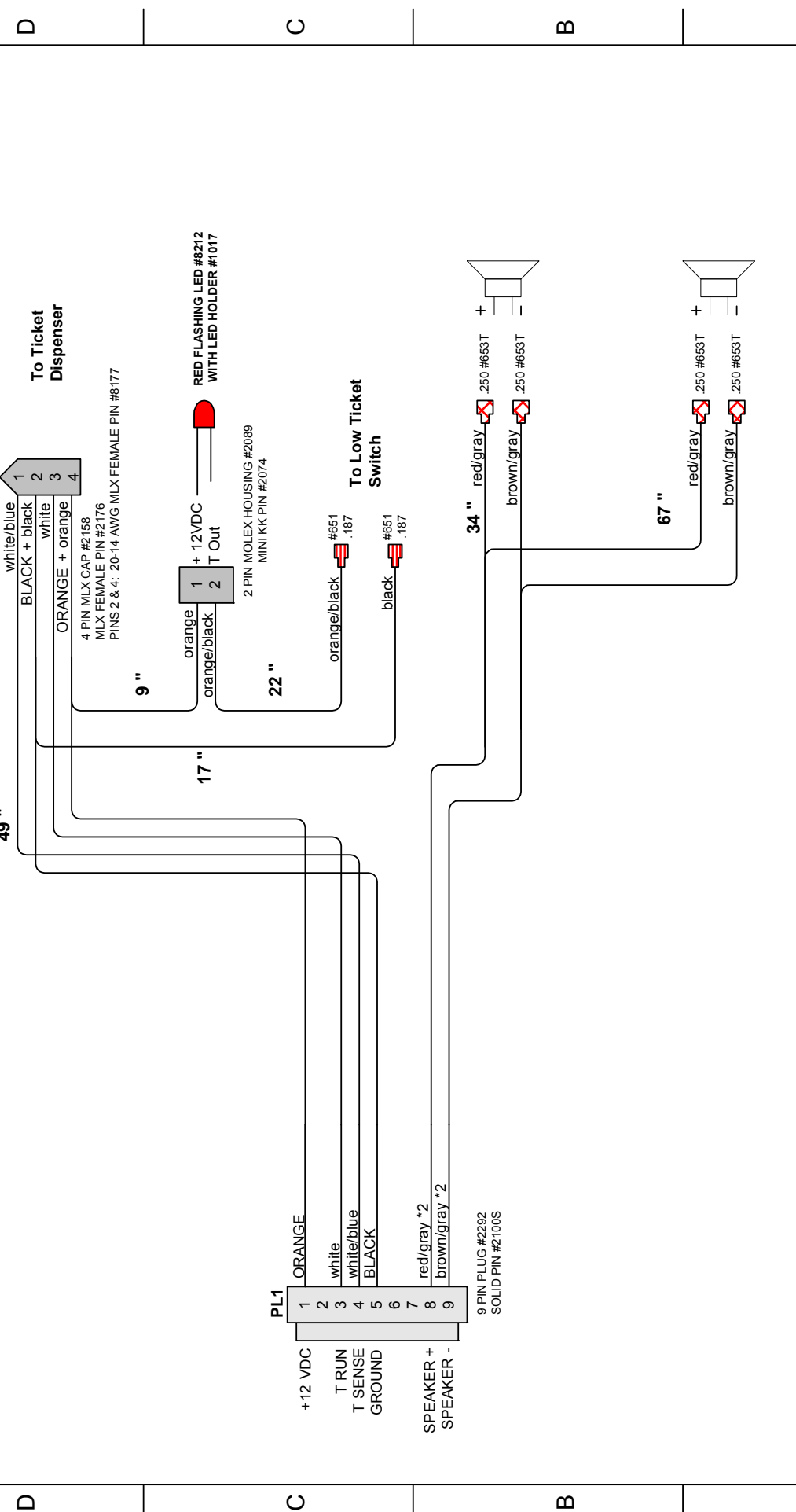

| | | | |
|-------------|--|-------------------|---------|
| TITLE | | ROCK N MOON RALLY | |
| DESCRIPTION | | FILENAME | RR.VSD |
| DATE | | DRAWN BY | MMARTIN |
| 8/15/01 | | REVISED | 6/17/02 |
| PAGE | | 3 OF 24 | |

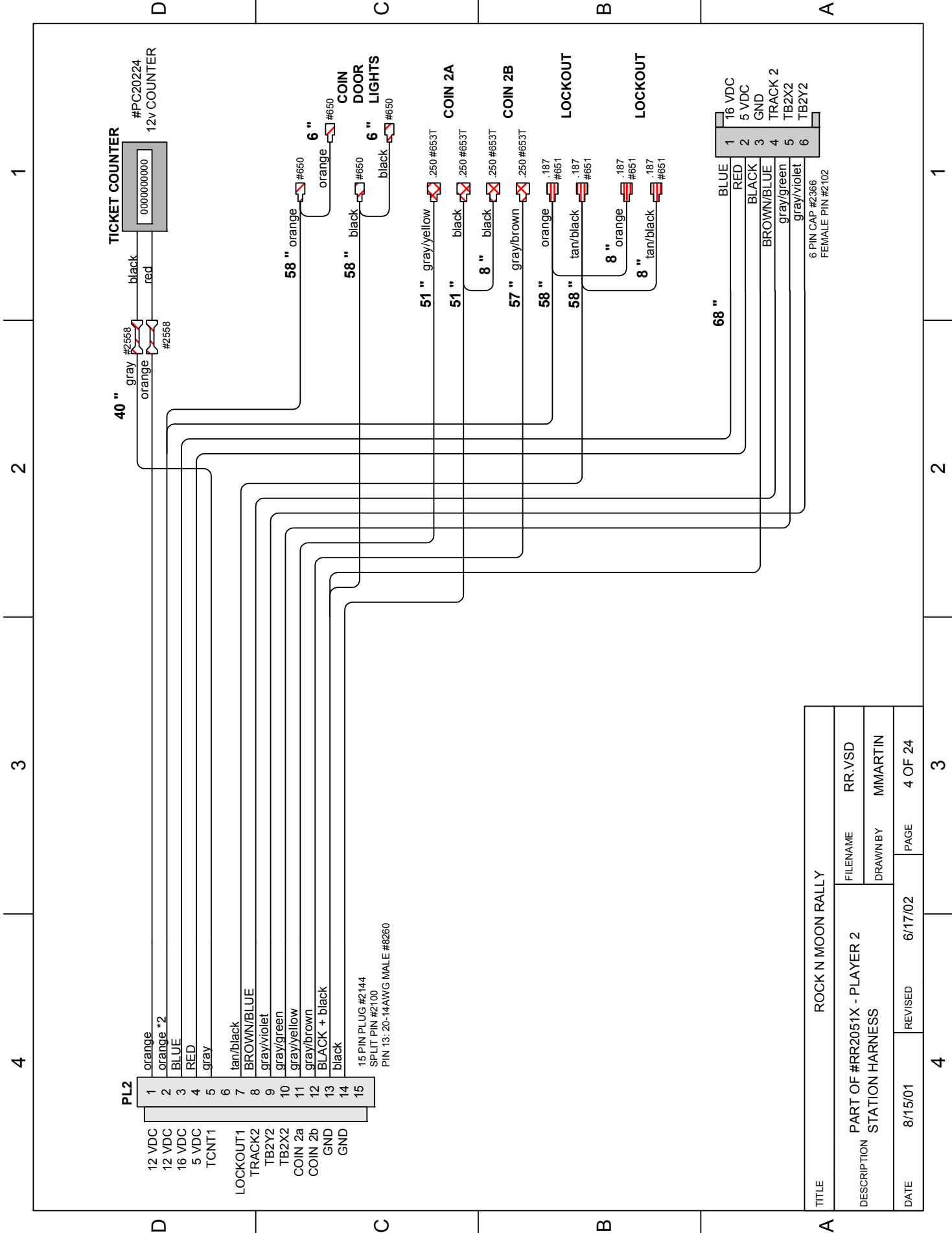

| | | | |
|-------------|---------|-------------------|--------------|
| TITLE | | ROCK N MOON RALLY | |
| DESCRIPTION | | FILENAME | RR.VSD |
| DATE | | DRAWN BY | MMARTIN |
| 8/15/01 | REVISED | 6/17/02 | PAGE 4 OF 24 |

1 2 3 4

D C B A

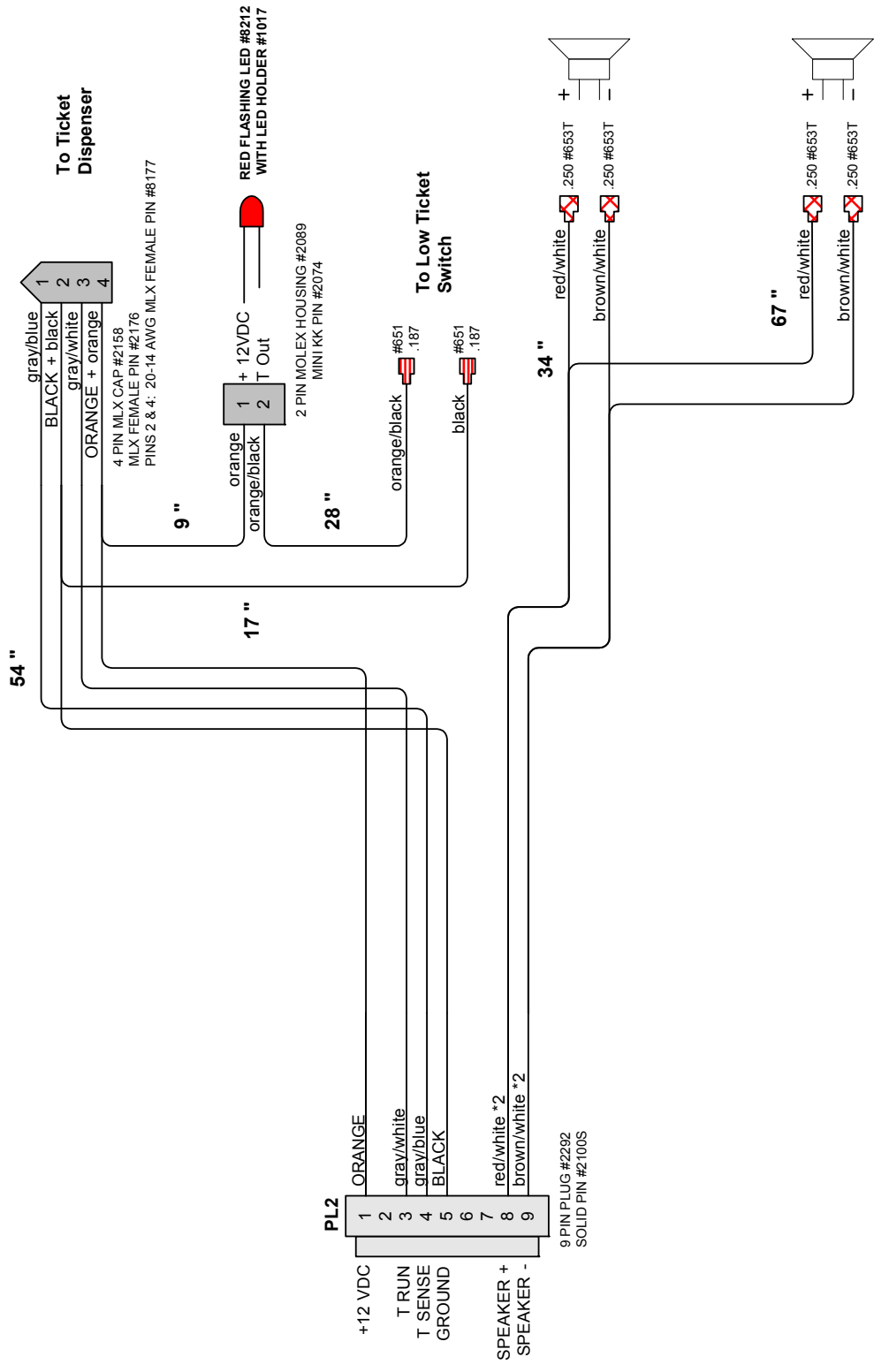

| | | | |
|-------------|---------|-------------------|--------------|
| TITLE | | ROCK N MOON RALLY | |
| DESCRIPTION | | FILENAME | RR.VSD |
| DATE | | DRAWN BY | MMARTIN |
| 8/15/01 | REVISED | 6/17/02 | PAGE 5 OF 24 |

1 2 3 4

1 2 3 4

D C B A

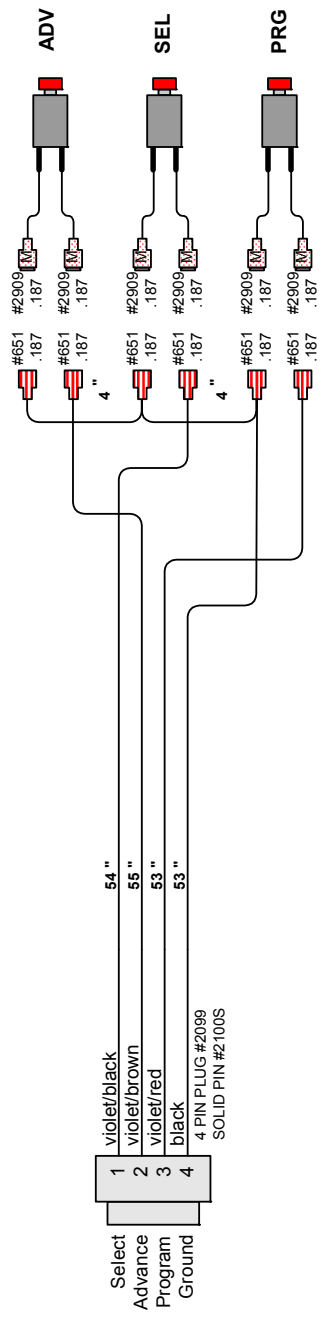

#WA1007 - BRACKET (RESET BUTTON)

| | | | |
|-----------------------------|---------|-------------------|---------|
| TITLE | | ROCK N MOON RALLY | |
| DESCRIPTION | | FILENAME | RR.VSD |
| PART OF #RR2051X - PLAYER 2 | | DRAWN/ BY | MMARTIN |
| DATE | REVISED | PAGE | 6 OF 24 |
| 8/15/01 | 6/17/02 | | |

1 2 3 4

1 2 3 4

To Marquee/Win/Halogen
Harness

To Power Module
Adapter

- 1 AC L
- 2 E GND
- 3 AC N
- 4 +16 VDC
- 5 WIN 1
- 6 WIN 2

- 1 BLACK
 - 2 GREEN
 - 3 WHITE
- 3 PIN PLUG #2206
SOLID PIN #2100S

#8173 - CABLE 3 COND SVT CORD BLACK
33"

52"

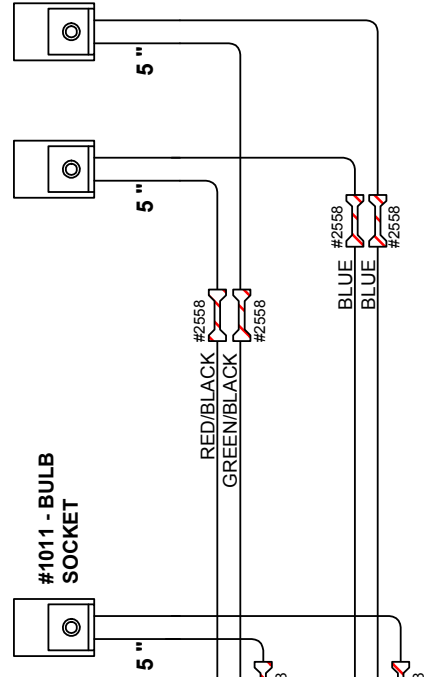

- P10**
- 1 RED/BLACK
 - 2 GREEN/BLACK
 - 3 Yellow/orange
 - 4 violet/orange
 - 5 TAN/BLACK
 - 6 KEY
 - 7
 - 8
 - 9
 - 10 BLUE
 - 11 BLUE
 - 12 BLUE
 - 13 blue
- LARGE LAKE 1
LARGE LAKE 2
WIN 1
WIN 2
SMALL LAKE 1
KEY
- + 16 VDC
+ 16 VDC
+ 16 VDC

13 PIN AMP HOUSING #8513
CONTACT PIN #2201
KEY PLUG #2239

TITLE ROCK N MOON RALLY

DESCRIPTION PART OF #RR2052X - LIGHTS/ROBOT
EXT. HARNESS

DATE 8/15/01 REVISED 6/17/02

FILENAME RR.VSD
DRAWN BY MMARTIN
PAGE 7 OF 24

1 2 3 4

4 3 2 1

D C B A

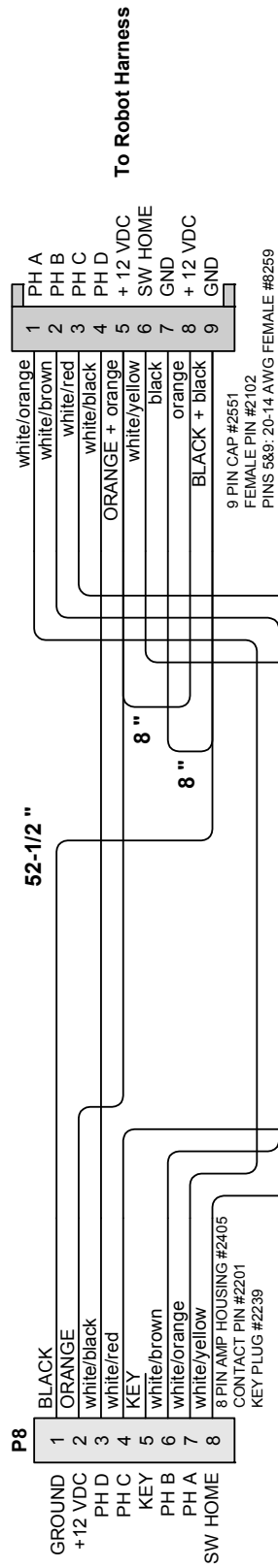

| | | | |
|--------------|---------|-------------------|--------------|
| TITLE | | ROCK N MOON RALLY | |
| DESCRIPTION | | FILENAME | RR.VSD |
| EXT. HARNESS | | DRAWN/BY | MMARTIN |
| DATE | REVISED | 6/17/02 | PAGE 8 OF 24 |
| 8/15/01 | | | |

4 3 2 1

D C B A

4 3 2 1

D C B A

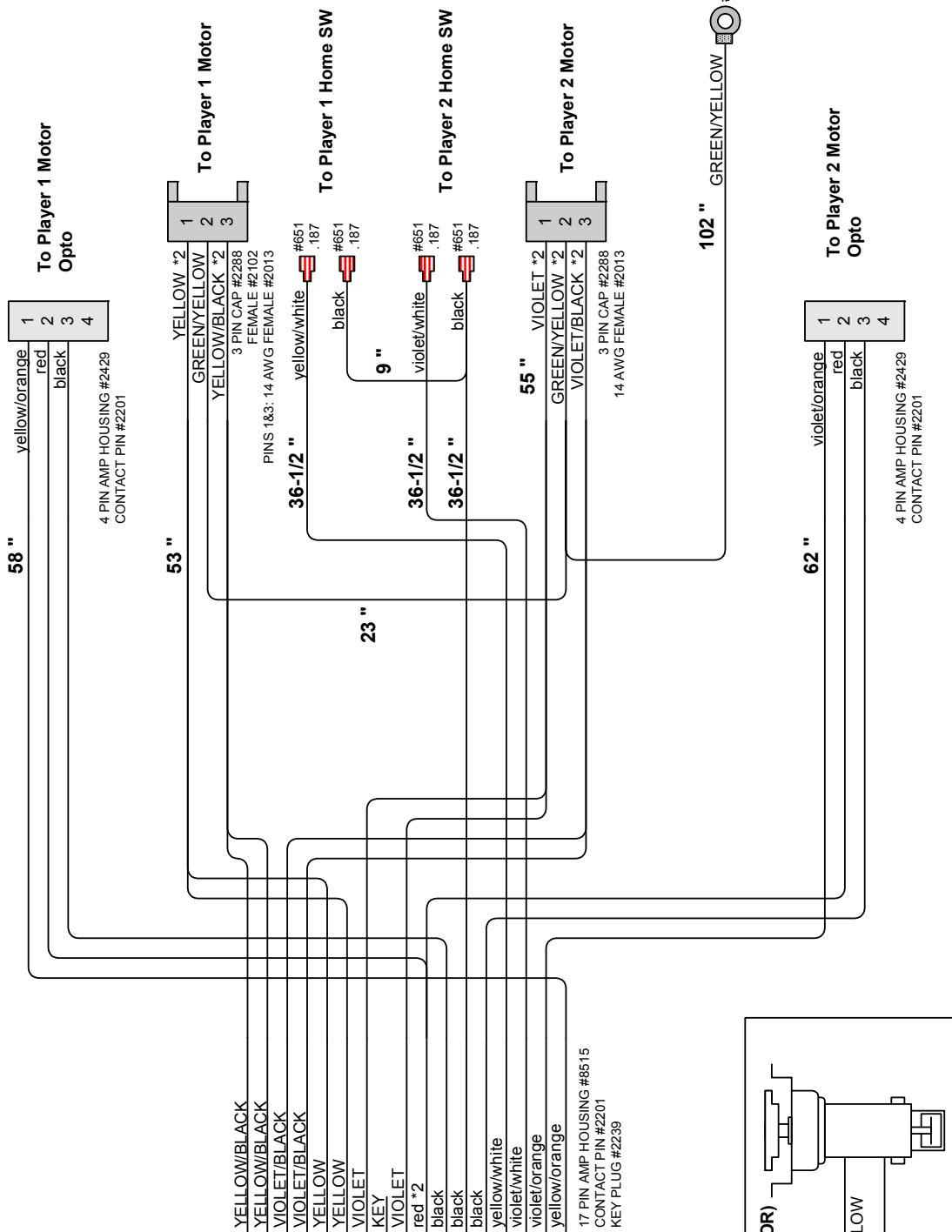

| | | |
|-------------|---|------------------|
| TITLE | ROCK N MOON RALLY | |
| DESCRIPTION | PART OF #RR2053X - MAIN CABINET HARNESS | FILENAME RR.VSD |
| DATE | 8/15/01 | DRAWN/BY MMARTIN |
| REVISED | 6/17/02 | PAGE 9 OF 24 |

4 3 2 1

D C B A

4 3 2 1

D C B A

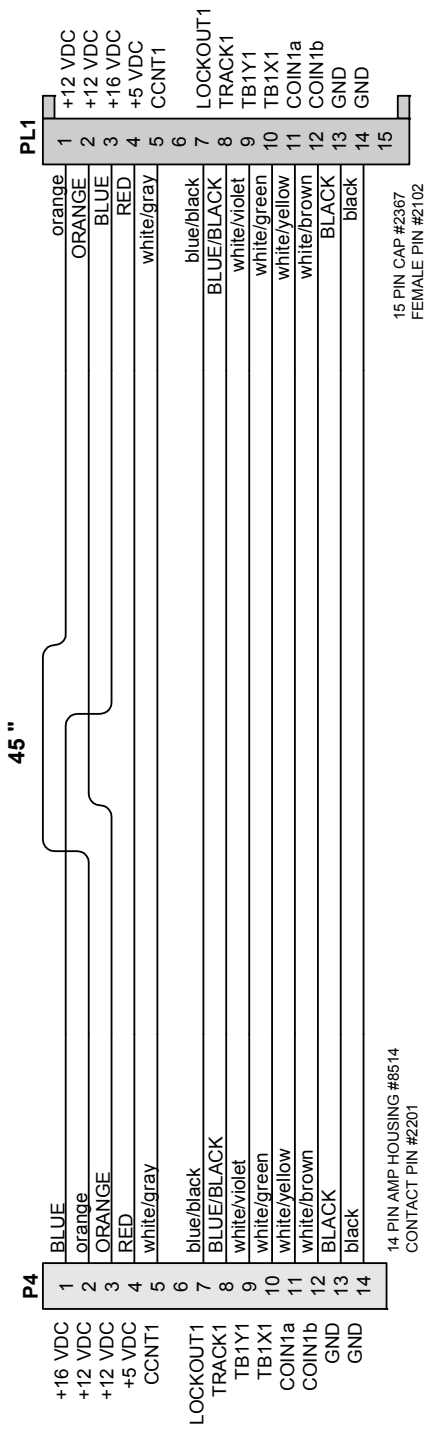

| | | | |
|-------------|---------|-------------------|---------|
| TITLE | | ROCK N MOON RALLY | |
| DESCRIPTION | | FILENAME | RR.VSD |
| DATE | | DRAWN BY | MMARTIN |
| 8/15/01 | REVISED | 6/17/02 | PAGE |
| 2 | 1 | 10 OF 24 | |

1 2 3 4

D C B A

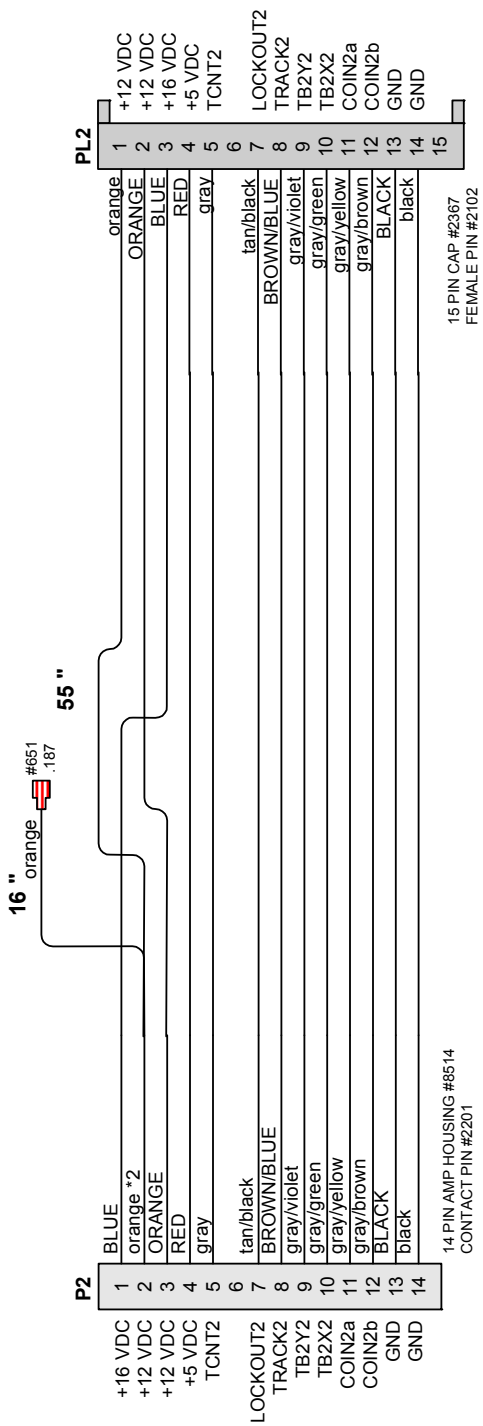

| | | | |
|-------------|----------|-------------------|---------|
| TITLE | | ROCK N MOON RALLY | |
| DESCRIPTION | | FILENAME | RR.VSD |
| DATE | | DRAWN BY | MMARTIN |
| 8/15/01 | REVISED | 6/17/02 | PAGE |
| 2 | 11 OF 24 | 1 | |

1 2 3 4

D C B A

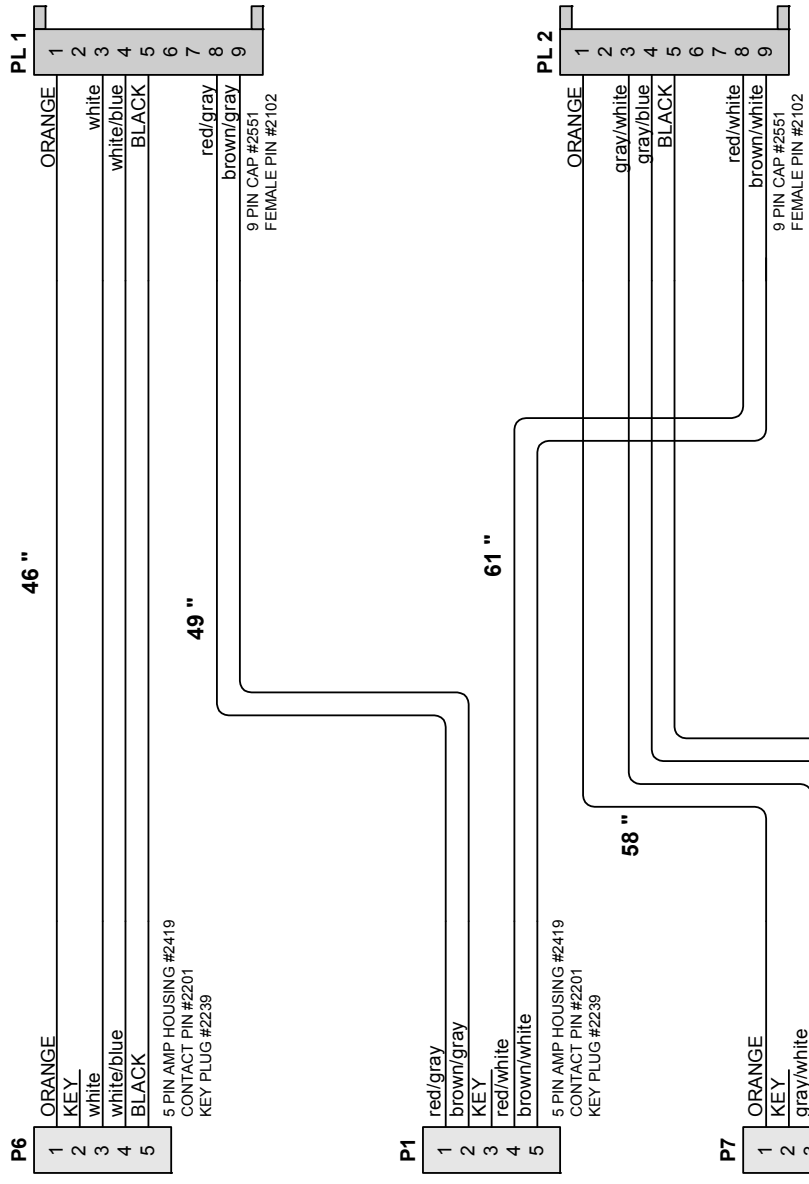

| | | | |
|-------------|---------|-------------------|----------|
| TITLE | | ROCK N MOON RALLY | |
| DESCRIPTION | | FILENAME | RR.VSD |
| DATE | | DRAWN BY | MMARTIN |
| 8/15/01 | REVISED | 6/17/02 | PAGE |
| | | | 12 OF 24 |

1 2 3 4

4 3 2 1

D D

C C

B B

A A

P11

- 1
- 2
- 3
- 4

violet/black
 violet/brown
 violet/red
 black

4 PIN AMP IDC #2561
 COVER #2562

62 "

- 1
- 2
- 3
- 4

violet/black
 violet/brown
 violet/red
 black

4 PIN CAP #2101
 FEMALE PIN #2102

To Button Harness On
 Player 2 Station

| | | | |
|--|---------|-------------------|----------|
| TITLE | | ROCK N MOON RALLY | |
| DESCRIPTION | | FILENAME | RR.VSD |
| PART OF #2053X - MAIN CABINET HARNESS | | DRAWN BY | MMARTIN |
| DATE | 8/15/01 | REVISED | 6/17/02 |
| | | PAGE | 13 OF 24 |

4 3 2 1

1 2 3 4

D C B A

To Main Board

| P5 | |
|----|-------------|
| 1 | ORANGE |
| 2 | ORANGE |
| 3 | brown/blue |
| 4 | brown/red |
| 5 | KEY |
| 6 | brown/green |
| 7 | BLACK |
| 8 | BLACK |

8 PIN AMP HOUSING #2405
CONTACT PIN #2201
KEY PLUG #2239

71"

| P1 | |
|----|-------------|
| 1 | BLACK |
| 2 | BLACK |
| 3 | KEY |
| 4 | brown/red |
| 5 | brown/green |
| 6 | brown/blue |
| 7 | ORANGE |
| 8 | ORANGE |

8 PIN AMP HOUSING #2405
CONTACT PIN #2201
KEY PLUG #2239

To Player 2 Display

| |
|---------|
| Ground |
| Ground |
| KEY |
| D CLK |
| D DATA |
| D LATCH |
| 12 VDC |
| 12 VDC |

TITLE ROCK N MOON RALLY

DESCRIPTION PART OF #RR2053X - MAIN CABINET HARNESS

FILENAME RR.VSD
DRAWN BY MMARTIN

DATE 8/15/01 REVISED 6/17/02 PAGE 14 OF 24

4 3 2 1

D C B A

4 3 2 1

D C B A

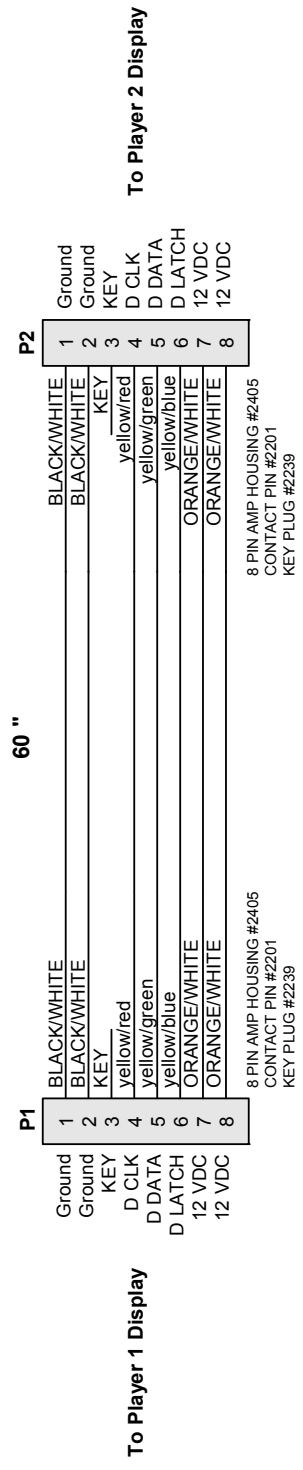

| | | | |
|---------------------------------|---------|-------------------|----------|
| TITLE | | ROCK N MOON RALLY | |
| DESCRIPTION | | FILENAME | RR.VSD |
| PART OF #RR2053X - MAIN CABINET | | DRAWN BY | MMARTIN |
| DATE | 8/15/01 | REVISED | 6/17/02 |
| | | PAGE | 15 OF 24 |

4 3 2 1

D C B A

4 3 2 1

D C B A

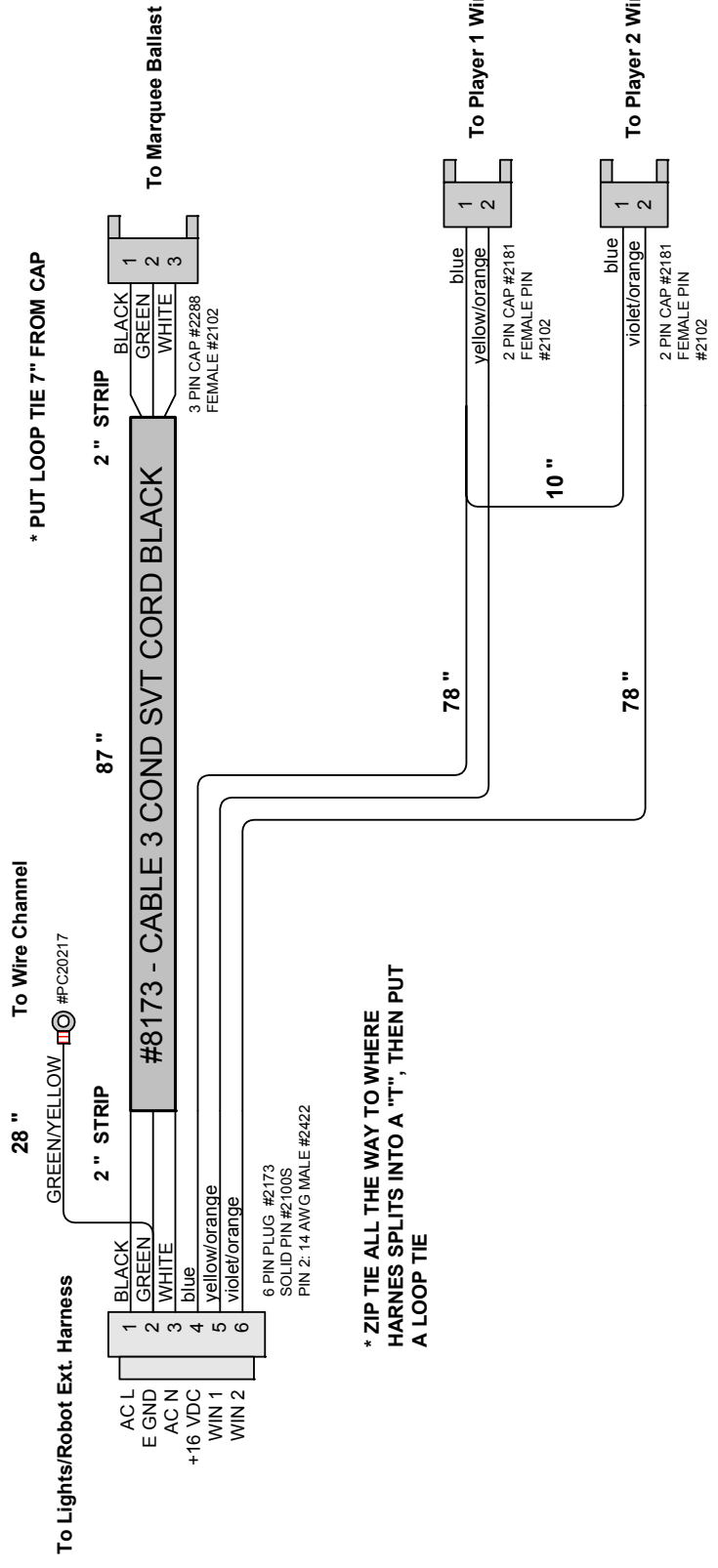

* PUT LOOP TIE 7" FROM CAP

To Marquee Ballast

* ZIP TIE ALL THE WAY TO WHERE HARNES SPLITS INTO A "T", THEN PUT A LOOP TIE

| | | | |
|-------------|--|-------------------|---------------|
| TITLE | | ROCK N MOON RALLY | |
| DESCRIPTION | PART OF #RR2058X - MARQUEE/WIN/ HALOGEN HARNES | FILENAME | RR.VSD |
| DATE | 8/15/01 | DRAWN BY | MMARTIN |
| | REVISED | 6/17/02 | PAGE 16 OF 24 |

4 3 2 1

1
2
3
4

D C B A

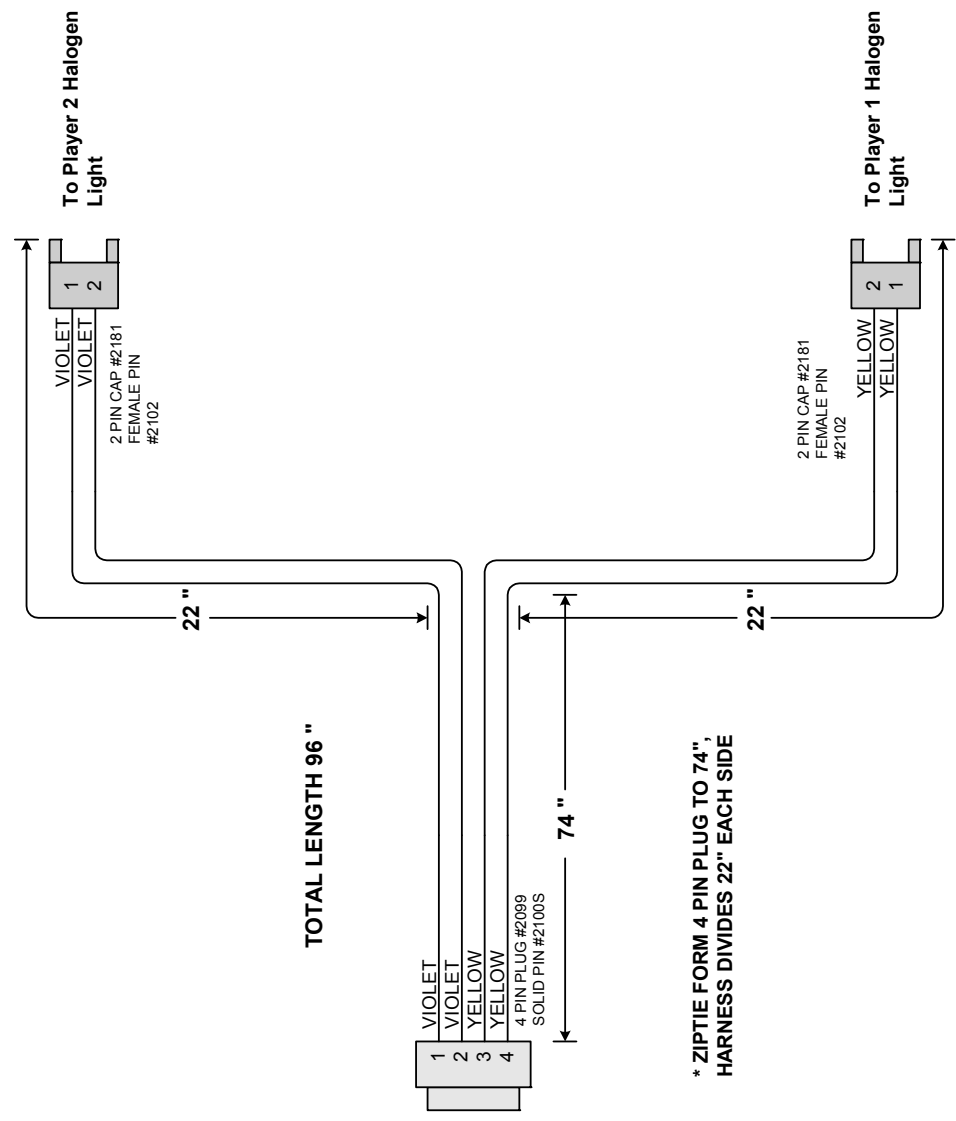

* ZIPTIE FORM 4 PIN PLUG TO 74",
HARNESS DIVIDES 22" EACH SIDE

| | | | |
|-------------|--|-------------------|---------|
| TITLE | | ROCK N MOON RALLY | |
| DESCRIPTION | | FILENAME | RR.VSD |
| DATE | | DRAWN BY | MMARTIN |
| 8/15/01 | | REVISED | 6/17/02 |
| PAGE | | 17 OF 24 | |

1
2
3
4

1 2 3 4

D C B A

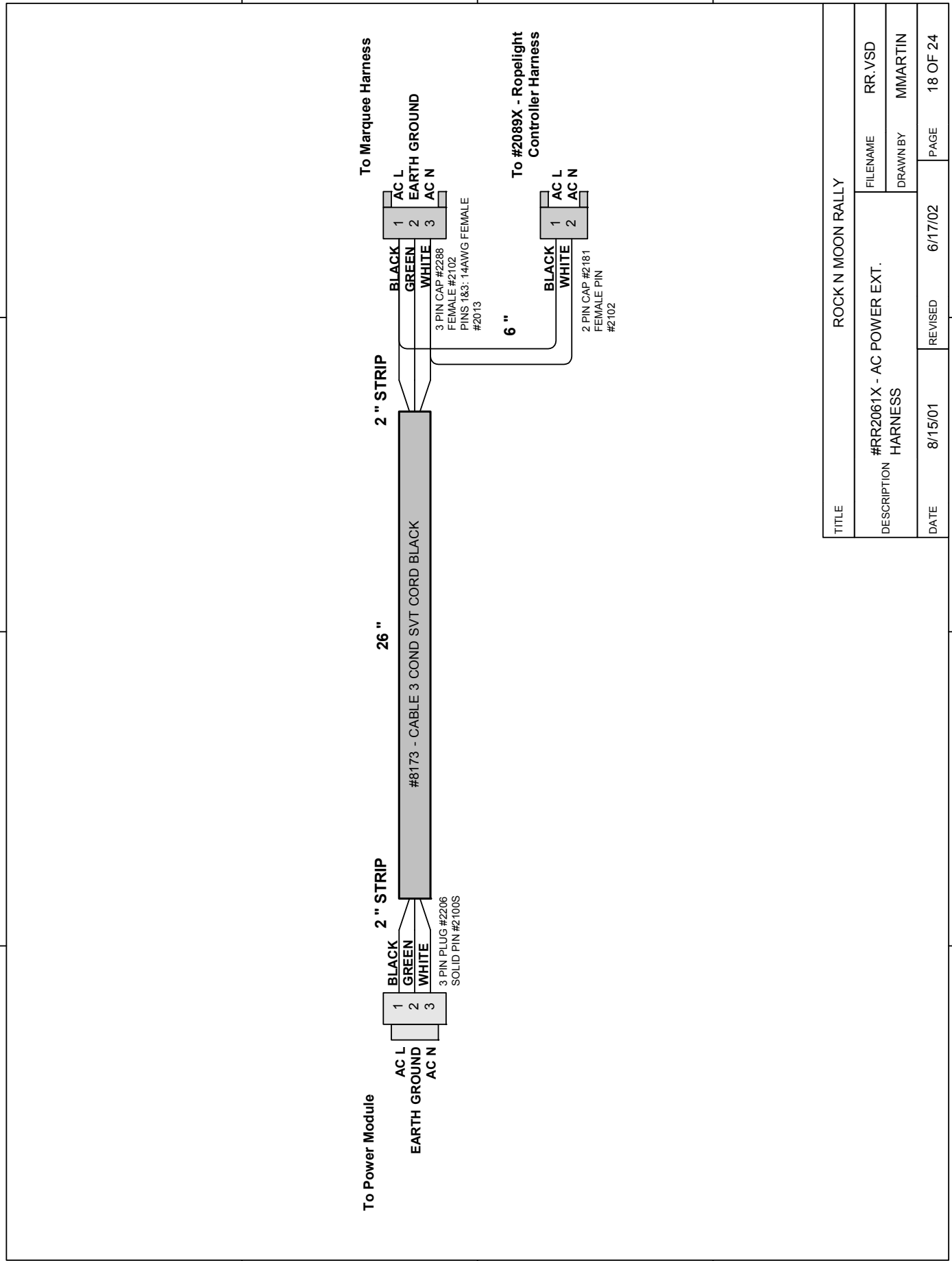

| | | | |
|-------------|---------|-------------------|----------|
| TITLE | | ROCK N MOON RALLY | |
| DESCRIPTION | | FILENAME | RR.VSD |
| HARNESS | | DRAWN BY | MMARTIN |
| DATE | REVISED | PAGE | 18 OF 24 |
| 8/15/01 | 6/17/02 | 1 | 1 |

1 2 3 4

D C B A

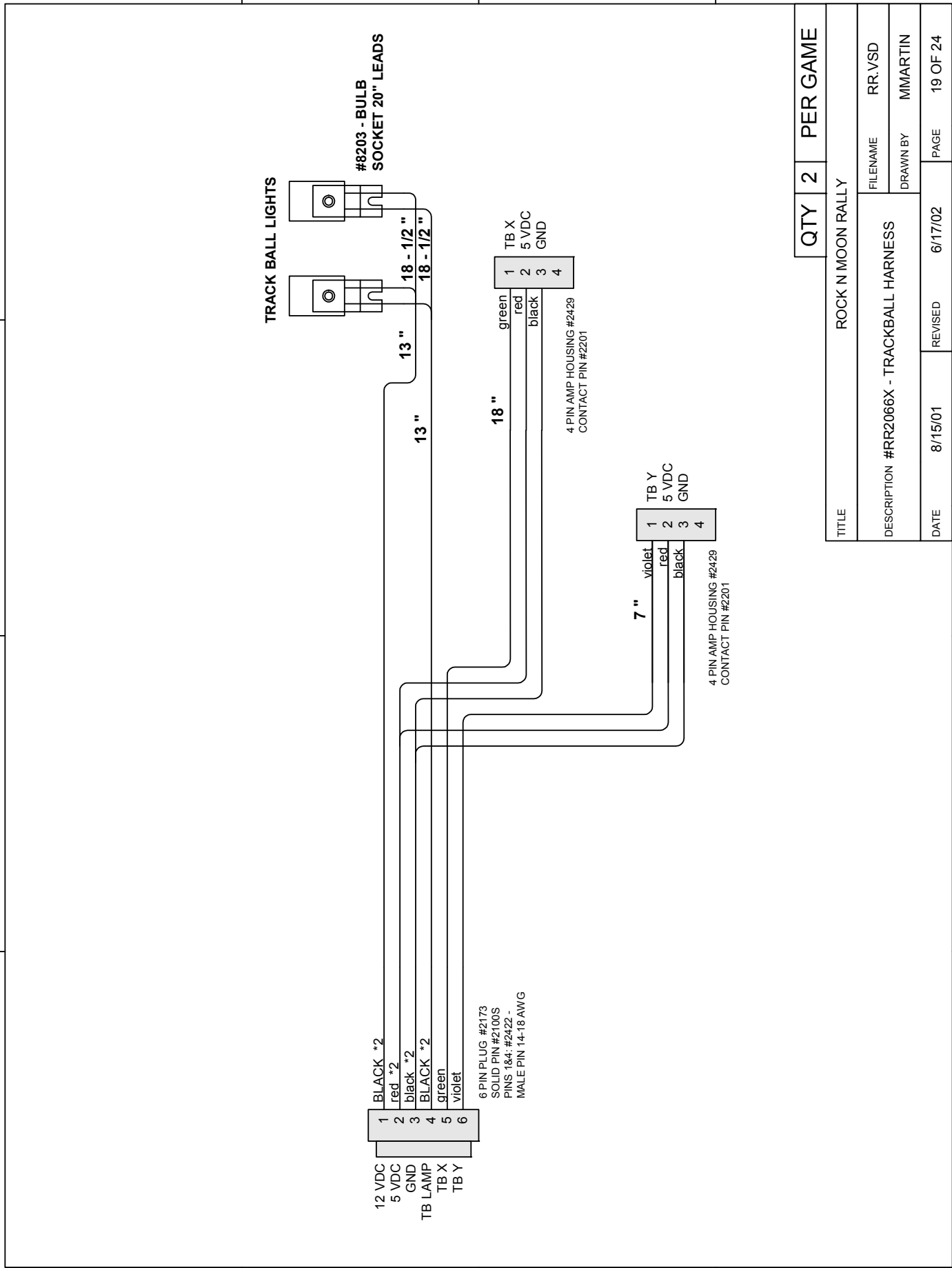

| | | |
|--|--------------------|---------------------|
| QTY 2 | | PER GAME |
| TITLE ROCK N MOON RALLY | | |
| DESCRIPTION #RR2066X - TRACKBALL HARNESS | | |
| DATE 8/15/01 | REVISED 6/17/02 | PAGE 19 OF 24 |
| FILENAME RR.VSD | | DRAWN BY MMARTIN |

1 2 3 4

D C B A

4 3 2 1

D C B A

To Ropelight Controller Board

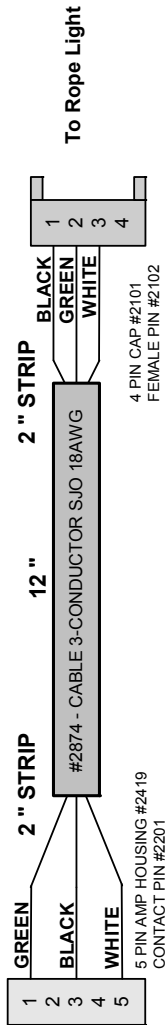

| | | | |
|-------------|---------|-------------------|---------|
| TITLE | | ROCK N MOON RALLY | |
| DESCRIPTION | | FILENAME | RR.VSD |
| DATE | | DRAWN BY | MMARTIN |
| 8/15/01 | REVISED | 6/17/02 | PAGE |
| 21 OF 24 | | 1 | |

4 3 2 1

D C B A

1
2
3
4

D C B A

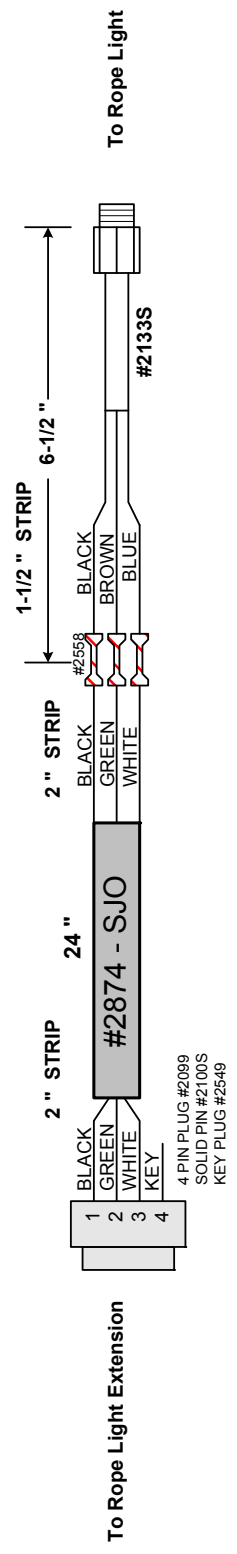

| | | | |
|--|---------|-------------------|---------------|
| TITLE | | ROCK N MOON RALLY | |
| DESCRIPTION #RRR2090X - ROPE LIGHT HARNESS | | FILENAME | RR.VSD |
| DATE | | DRAWN/BY | MMARTIN |
| 8/15/01 | REVISED | 6/17/02 | PAGE 22 OF 24 |

1
2
3
4

1 2 3 4

D C B A

#RR1026-P802 - BRACKET LAMP

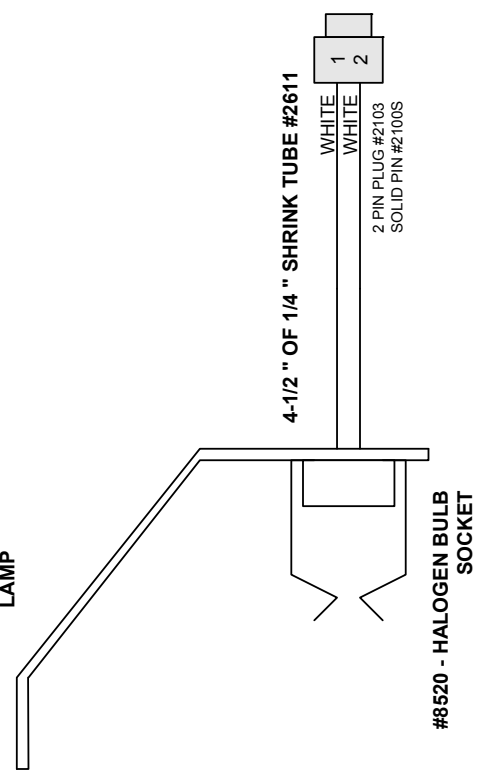

- 1.) HARNESSING WILL STRIP AND PUT ON PINS
- 2.) FLOOR WILL INSERT SOCKET THROUGH BRACKET
- 3.) PUT ON SCREWS
- 4.) PUT 4-1/2 " OF 1/4 " SHRINK TUBE OVER WIRES(DO NOT SHRINK)
- 5.) PLUG WIRES INTO 2 PIN PLUG

| | | | |
|-------------|---------|-------------------|----------|
| TITLE | | ROCK N MOON RALLY | |
| DESCRIPTION | | FILENAME | RR.VSD |
| DATE | | DRAWN BY | MMARTIN |
| 8/15/01 | REVISED | 6/17/02 | PAGE |
| | | | 23 OF 24 |

1 2 3 4

4 3 2 1

D C B A

#2089X-AC ROPE LIGHT HARNESS

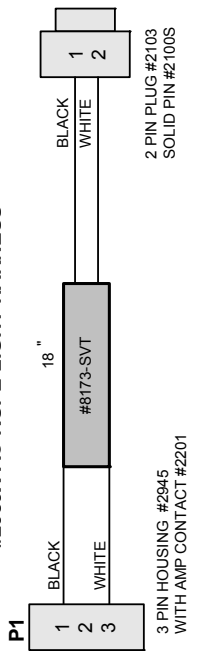

TITLE ROCK N MOON RALLY

| | |
|--|------------------|
| DESCRIPTION #2089X - AC ROPE LIGHT HARNESS | FILENAME RR.VSD |
| | DRAWN BY MMARTIN |

| | | |
|--------------|-----------------|---------------|
| DATE 8/15/01 | REVISED 6/17/02 | PAGE 24 OF 24 |
|--------------|-----------------|---------------|

4 3 2 1

WARRANTY

I.C.E warrants all components in the **Rock'N Moon Rally™** game to be free of defects in materials and workmanship for a period of ninety days from the date of purchase.

This warranty does not cover items damaged due to normal wear and tear, subjected to abuse, improperly assembled by the end user, modified, repaired, or operated in a fashion other than that described in the service manual.

If your **Rock'N Moon Rally™** game fails to conform to the above-mentioned warranty, I.C.E.'s sole responsibility shall be at its discretion to repair or replace any defective component with a new or remanufactured component of equal to or greater O.E.M. specification.

I.C.E. will assume no liability whatsoever, for costs associated with labor to replace defective parts, or travel time associated therein.

I.C.E.'s obligation will be to ship free of charge, replacement parts by domestic U.P.S. Ground, U.S. mail, or other comparable shipping means. Any express mail or overnight shipping expense is at the cost of the purchaser.

Products will be covered under warranty only when:

- The serial number of the game with the defective parts is given.
- The serial number of the defective part, if applicable, is given.
- Defective parts are returned to I.C.E., shipping pre-paid, in a timely fashion, if requested by I.C.E.
- A copy of the sales receipt is available as proof of purchase upon request of I.C.E.

I.C.E. distributors are independent, privately owned and operated. In their judgment, they may sell parts or accessories other than those manufactured by I.C.E. We cannot be responsible for the quality, suitability, or safety of any non-I.C.E. part, or any modification, including labor, which is performed by such a distributor.



WARRANTY

ICE Inc warrants that all of its products will be free from defects in material and workmanship.

When placing a warranty request, please be prepared to provide the following information:

- Serial Number of Game or Bill of Sale
- Machine Type
- A Detailed Description of the Equipment Fault Symptoms

ICE product, including Cromptons, Sam's Billiards, Uniana and Bell Fruit is warranted as follows:

- 180 days on the Main PCB and Computers
- 180 days on Motors
- 90 days on all other components (i.e. DBV's, Ticket Dispensers, etc)
- 30 days on repaired items
- 3 years on all Crane Harnessing
- 9 Months on Printers

ICE Inc shall not be obligated to furnish a warranty request under the following conditions:

- Equipment has been subjected to unwarranted stress through abuse or neglect
- Equipment has been damaged as a result of arbitrary repair/modification attempts
- Equipment that has failed through normal wear and tear

ICE Inc will assume no liability whatsoever for costs associated with labor to replace defective parts or travel time associated therein.

All defective warranty covered components will be replaced with new or factory refurbished components equal to OEM specifications. ICE Inc will cover all domestic UPS ground, or comparable shipping means, freight costs during the warranty period. Expedited shipments are available for an additional charge.

Defective parts are returned to ICE Inc, at the customer's expense, in a timely fashion.

ICE distributors are independent, privately owned and operated. In their judgment, they may sell parts and/or accessories other than those manufactured by ICE Inc. We cannot be responsible for the quality, suitability or safety of any non-ICE part, modification (including labor) that is performed by such a distributor.

I.C.E. Parts/Service Dept.
Innovative Concepts in Entertainment
10123 Main St.
Clarence, NY 14031
Phone #: (716) - 759 - 0360
Fax #: (716) - 759 - 0884